

ROTARY TROCHOIDAL PUMPS



*For all your  
Pumping needs since 1968...*

## **Series DRT**



## **Series DRTBP**



The DRT / DRTBP pumps are based on the proven Rotary Trochoidal design - Gerotor principle. The pumps are designed to meet specific demands of OEMs.

The reliable performance of the DRT / DRTBP series makes them an ideal choice for various industrial applications.

## EXPLODED VIEW OF DRT SERIES PUMP

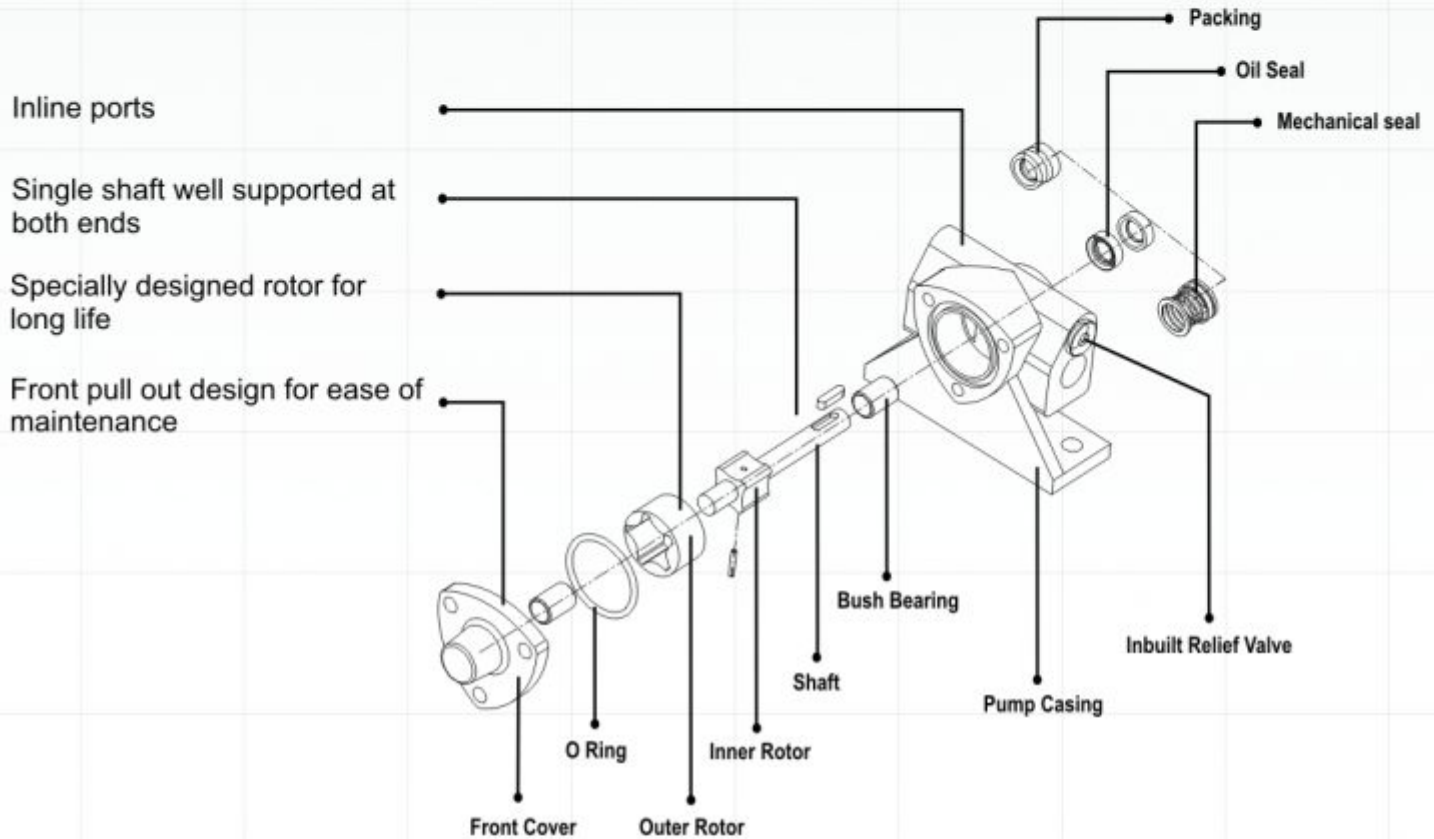

### Typical Application

- ▶▶ Transfer from tank to tank
- ▶▶ Emptying of barrels
- ▶▶ Lubricating and cooling of bearings, gears, mechanical seals and machine tools
- ▶▶ Fuel oil booster

### Liquids Handled

- ▶▶ Fuel Oil
- ▶▶ Lube Oil
- ▶▶ Neutral liquids with lubricating properties

### Special Executions

- ▶▶ Specially coated internals for pumping of non-lubricating liquids.
- ▶▶ Engineering plastics rotor set for chemicals & low viscosity fluids
- ▶▶ Specially designed pumps for vacuum duty applications
- ▶▶ Uni-directional

### Advantages of DRT / DRTBP Pumps

- ▶▶ Single shaft - well supported at both ends
- ▶▶ High suction lift and low noise level as well as vibrations
- ▶▶ High volumetric and overall efficiency
- ▶▶ Continuous, pulsation free flow due to axial entry in pumping element
- ▶▶ Compact and light-weight design
- ▶▶ Ease of assembling and dismantling without disturbing the pipeline.
- ▶▶ Choice of oil seal / mechanical seal / gland pack
- ▶▶ Parts / Pumps interchangeable with well known brands

## EXPLODED VIEW OF DRTBP SERIES PUMP

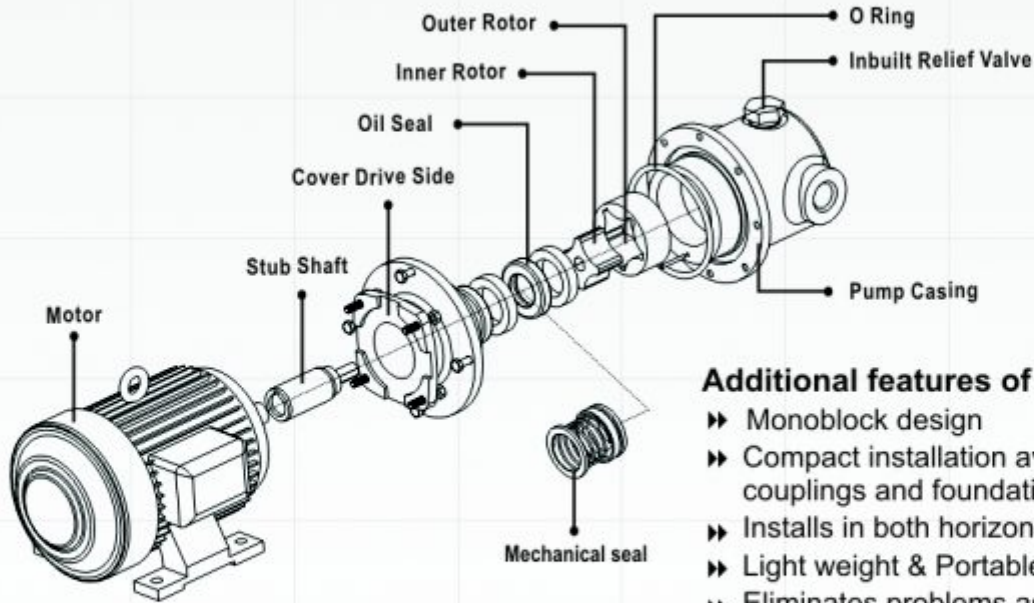

### Additional features of DRTBP Pumps

- ▶▶ Monoblock design
- ▶▶ Compact installation avoiding base plate, couplings and foundation
- ▶▶ Installs in both horizontal and vertical positions
- ▶▶ Light weight & Portable
- ▶▶ Eliminates problems associated with shaft alignment

### DRT / DRT-BP PERFORMANCE CHART @ 1440 rpm

Pump Model	Lube Oil - Viscosity 40 Cst					
	Diff. Press - Bar	0	2	4	6	8
DRT-03	LPM	3.8	3.7	3.4	3.2	-
	kW	0.09	0.1	0.12	0.15	-
DRT / DRTBP-05	LPM	7	6.5	6	5	-
	kW	0.1	0.18	0.23	0.28	-
DRT / DRTBP-10	LPM	11.7	11.5	11.1	10.6	10
	kW	0.17	0.23	0.28	0.35	0.46
DRT-15	LPM	17.5	16.9	16	15.4	15
	kW	0.25	0.3	0.39	0.49	0.58
DRT / DRTBP-20	LPM	24.9	23.8	22	21	19
	kW	0.27	0.37	0.46	0.56	0.7
DRT / DRTBP-40	LPM	44	43	42	41	40
	kW	0.22	0.31	0.5	0.7	0.84
DRT-80	LPM	85	83	82	81	77
	kW	0.6	0.7	1.1	1.5	1.9
DRT-125/32	LPM	131	129	125	122	120
	kW	1.25	1.6	2.02	2.58	3.19
DRT-125/38	LPM	156	153	151	148	145
	kW	1.35	1.81	2.32	2.40	3.9
DRT-125/50	LPM	200	195	189	184	177
	kW	1.5	2	2.66	3.45	4.13

Contact us with your application details for a suitable recommendation.

SUCTION & DISCHARGE.

MODEL	SUCT. & DISC
DRT-03	1/4" B.S.P
DRT-05	1/2" B.S.P
DRT-10	1/2" B.S.P
DRT-15	1/2" B.S.P
DRT-20	1/2" B.S.P
DRT-40	1" B.S.P
DRT-80	1 1/2" B.S.P
DRT-125	1 1/2" B.S.P

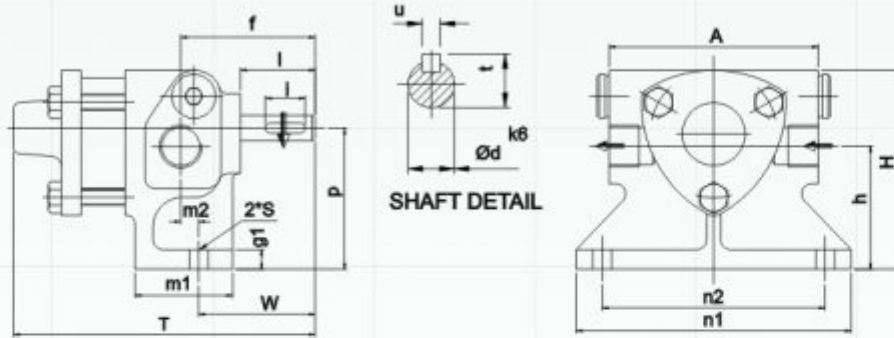

MODEL	A	H	T	W	d	f	g1	h	l	l	m1	m2	n1	n2	p	t	u	S
DRT-03	80	128	72	77	8	34	5	88	15	20	N.A.	N.A.	100	131	90	6.5	N.A.	7
DRT-05	105	100	130	58.5	12.7	67.5	10	62	20	37.5	49	9	138	112	71	14.7	5	9.5
DRT-10	105	100	130	58.5	12.7	67.5	10	62	20	37.5	49	9	138	112	71	14.7	5	9.5
DRT-15	105	100	142	58.5	12.7	67.5	10	62	20	37.5	49	9	138	112	71	14.7	5	9.5
DRT-20	105	100	154	58.5	12.7	67.5	10	62	20	37.5	49	9	138	112	71	14.7	5	9.5
DRT-40	134	144	178	113.5	15	95.5	10	75	20	55.5	30	18	142	125	80	17.5	5	10
DRT-80	130	155	191	98.5	15	82	16	85	20	42.5	31.5	16.5	174	140	90	17.5	5	12
DRT-125	200	300	275	194	24	173	15	107	25	137	50	21	224	190	112	26.5	8	14

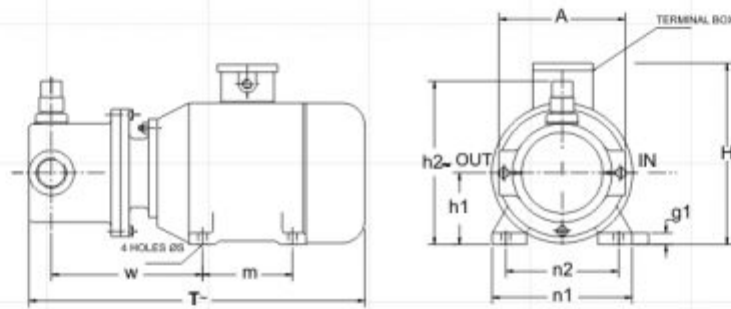

MODEL	FRAME	T	g1	h1	h2	m	n1	n2	H	A	w	s	SUCT & DISC.
DRTBP-05	F71	325	8	71	150	90	138	112	185	98	131	Ø7x10	1/2" BSP
DRTBP-10	F71	325	8	71	150	90	138	112	185	98	131	Ø7x10	1/2" BSP
DRTBP-20	F80	385	10	80	185	100	155	125	210	140	167.4	Ø10x14	3/4" BSP
DRTBP-40	F80	385	10	80	185	100	155	125	210	140	167.4	Ø10x14	3/4" BSP

All dimensions in mm

**We also manufacture:**

Gear Pumps, Progressive Cavity Pumps, Two Spindle Screw Pumps, Three Spindle Screw Pumps, Centrifugal Pumps, Filters & Lubricating systems

Capacity upto 20,000 LPM, Pressures upto 300 bar.

**Delta P D Pumps Pvt. Ltd.**

201, Wadala Udyog Bhavan, Naigaum Cross Road, Wadala, Mumbai – 400 031, INDIA.  
 Web: [www.deltapdpumps.com](http://www.deltapdpumps.com) | E-mail : [info@deltapdpumps.com](mailto:info@deltapdpumps.com)  
 Phone : (+91) 22 2415 3185 | Fax: (+ 91) 22 2414 3299